

The Precision Spherical Dipole Source

Freedom to
make accurate
and
repeatable
measurements
at Last!!



Xtreme Accuracy and Repeatability!!

a highly accurate electromagnetically-isolated and repeatable Electric field source.

Ideal for

- Precise and NIST-Traceable RF Emissions
- Highly Accurate Antenna Measurements
- Ultra-repeatable Shielding Measurements
- Ideal for Complex Site Calibration

Features

- Radiating Spherical Dipole Frequency Ranges:
 - 100 KHz to 50 MHz
 - 10 MHz to 2.5 GHz
- Antenna Optically Isolated from Control Unit
- Rechargeable Battery-Powered Dipole Antenna
- RF Level Monitoring at Dipole Output
- Temperature Controlled Laser Source



Applied Electromagnetic Technology

P.O. Box 1437, Solomons, Maryland 20688-1437, Phone: (410) 326-6728, Fax: (410) 326-6728
info@appliedemtech.com • www.appliedemtech.com

Advanced technology for accurate electromagnetic measurements

Precision Spherical Dipole Source

Control Unit

- Wide RF Input Frequency and Power Range
- Duplex Optical Fibers to Sphere for Total Isolation
- Monitored and Adjustable Output RF Power



Spherical Dipole Antenna

- Two PSDS Radiating Elements; High and Low Frequency Ranges
- Battery Operated for RF Isolation; 6 Hours of Operating Time
- Spheres Are Interchangeable With Same Control Unit

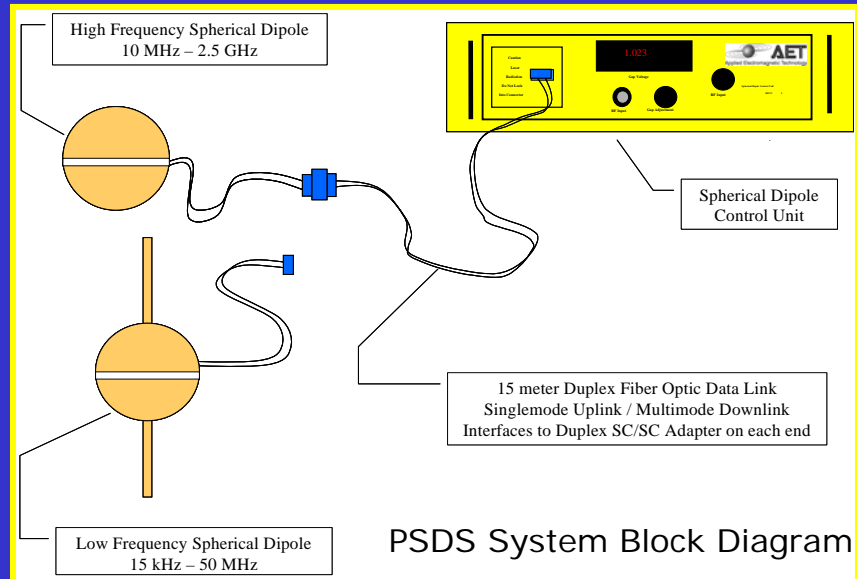

Batteries

- Two Ni-MH Rechargeable Battery Cards Inside the Sphere
- Designed to Provide Extra Long Spherical Dipole Operating Time
- Easy In-Sphere & External Charging for Real-World Applications

The Precision Spherical Dipole System (PSDS) was designed to be the real-world industry standard, and is the most versatile, accurate and reliable, electric field source available!

The PSDS is a unique product, a radiated E-field source that addresses many requirements in both the research and test community. This RF signal is optically transmitted to the spherical antenna, re-converted to RF, and radiated from the spherical dipole antenna. The antenna's gap voltage is monitored within the sphere and fed back via an optical fiber cable and displayed on the control unit's front panel. The radiated E-field level can be adjusted using the gap voltage measurement to create a highly repeatable (0.2 - 0.5 dB) and accurate E-field source.

Calibration Standard

Ideal as a calibrated reference source for daily equipment checks, and as an inter-laboratory and/or a multiple site transfer standard. Applicable to OATS, GTEMs, semi-anechoic or shielded rooms, and any standard RF test site or complex test environment.

Shielding Effectiveness Testing

The small radiating element (10cm. in diameter) makes the PSDS source ideal for inside very small (or large) enclosures for shielding effectiveness measurements. The gap voltage adjustment ensures the same radiating source electric field as in the open calibration characterization.

Antenna Calibration

Extremely stable and repeatable E-field source, and also electrically small, providing an accurate "point source" for antenna calibration. Fiber optic cables and battery isolation allow a repeatable test set-up, removing unwanted effects from coaxial cables, power cables, and ground loops.

